

Compact power,
concentrated functionality.



The new VARIODRIVE Compact motor
VDC-3-49.15

The engineer's choice

ebmpapst

Compact as a small motor, strong as a large motor and more intelligent than both of them together.

In countless applications, countless small drive units provide reliable service. Here, compact internal rotor motors are commonly known as an "all-purpose tool". However, these motors derive their power either from their overall length or the speed, frequently require multi-stage reduction gears and thus take up considerable installation space. Our answer to the lack of space: more power density. The VDC-3-49.15 is an extremely compact external rotor motor with high dynamics and constant torque over a wide speed range. Extensive additional options, outstanding performance data and versatility in use allow it to reach a class otherwise reserved for internal rotor motors.

From 0 to 100 watts in 5.2 centimetres

When high output is required but only limited installation space is available, power density is the most important keyword. Therefore, an optimum ratio of rated output and size was one of the most important factors in developing the new VARIODRIVE Compact motor VDC-3-49.15. The performance data of both motor designs (rated voltage 48 or 24 VDC) speak for themselves.

With a diameter of 63 mm and a length of just 52 mm, both versions are substantially shorter than comparable internal rotor motors. At a nominal speed of 4000 rpm each, they attain a rated torque of 250 mNm or 150 mNm. The high overload capacity allows start-up torques that are twice that high. At a current draw of 2.9 A (48 V) and 3.5 A (24 V), the drives have a continuous output of 105 W and 63 W, respectively.

The integrated electronics controls all motor functions of the VDC-3-49.15 and transmits the relevant operating data to the customer interface if required. Depending on the application, this may allow any special motor configurations necessary to be created by simple parameter configuration or programming the electronic control system. This reduces costs for development, production and stock-keeping.

Maximum performance with sensitivity

As the developer of the world's best compact fans, we are known for our external rotor motors. Though the requirements of a universally usable drive motor differ greatly from those of a fan motor, our engineers used their enormous wealth of experience for further development of the external rotor motor principle. The result is something astounding: The VDC-3-49.15 is a multi-pole external rotor motor with a completely integrated state-of-the-art electronic control unit that combines compactness with power, intelligence and precision.

In the new series, high overload capacity and a large starting torque provide the necessary punch. The considerable torque can be used over a wide speed range with consistently high efficiency. The motors attain dynamic values which, when additional external moments of inertia have to be moved, approach those of internal rotor motors. Thus they are also well suited for applications in which internal rotor motors were used previously, as long as their dynamic capabilities were not used to full capacity.

When high sensitivity is required, the powerful DSP (Digital Signal Processor) and the well-engineered software fully exploit their strengths. The continuous sinus commutation of all 3 winding phases enables accurate control of the drives, in an extremely wide speed range. For example, the VDC-3-49.15 can be controlled with its nominal torque at 0 rpm and also has considerable speed control quality without additional sensors, starting at the lowest speeds.

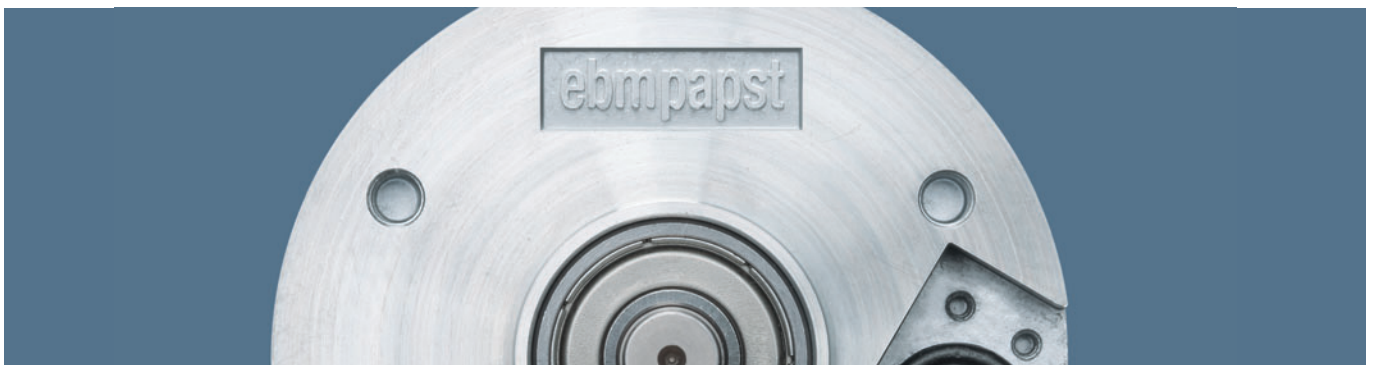

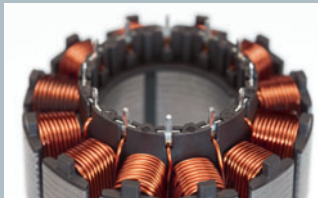

As versatile as the range of applications

The VDC-3-49.15's compact design makes it a definitive choice for manifold applications requiring minimal space and maximum performance. In addition, even more potential lies in its inner features. Their characteristic strengths make the drives suitable solutions in a wide variety of advanced application areas.

In the medical device and technology industry, they power sensitive metering pumps with a wide adjusting range, e. g. peristaltic pumps in dialysis machines. They can also be used for force- and distance-controlled operation for rehabilitation devices. In packaging technology and the textile industry, the adjustable torque limitation and accurate closed loop speed control allow optimum adaptation of winder drives to the materials used.

Integrated into a bus system, the motors can be used in automation, such as a drive for format adjustment or as a feed drive. For electronic gearboxes such as those in letter distribution systems, the drive is equipped optimally with the optional bus interface, its integrated 4-quadrant speed control electronics, the high overload capacity and the digital fault output.

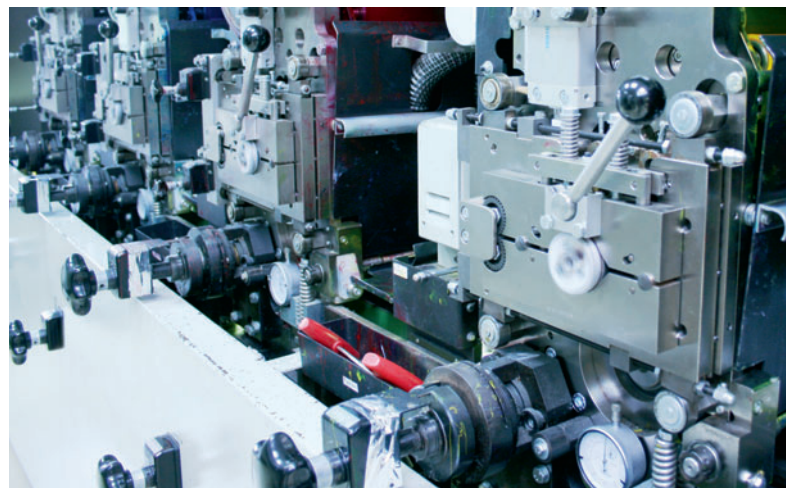

Performance advantages at a glance

- Compact design
- Exceptionally high power density
- Stiff speed-torque curve
- High overload capacity
- Extremely wide speed control range
- Holding torque at $n = 0$ rpm
- High dynamics, comparable to a DC-Motor
- Robust housing and bearing system
- Long service life
- Protection class IP 54, standard

VARIODRIVE Compact motor

VDC-3-49.15

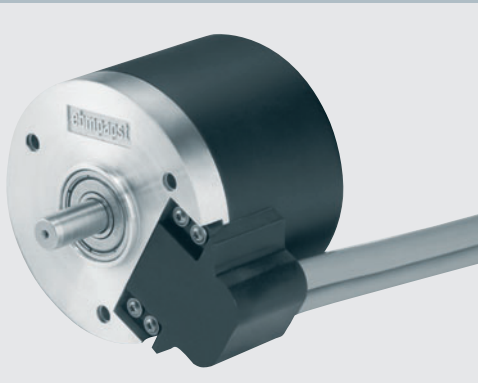

- 3-phase external rotor motor in EC technology.
- Rotor with multi-pole magnetised neodymium magnet.
- High power density with compact model.
- Integrated operating electronics with high-performance DSP.
- Excellent control behaviour with field-oriented control with sinus commutation.
- Extensive interface for variety of functions and operating mode selection.
- Overload protection with integrated temperature shutoff.
- Robust mechanical design with aluminium cover and sealed connector system.

Nominal data

Type		VDC-3-49.15 24 V	... 48 V
Nominal voltage (U_{BN})	V DC	24 (18 ... 30)	48 (18 ... 55)
Nominal speed (n_n)	rpm	4000	4000
Nominal torque (M_n)	mNm	150	250
Nominal current (I_{BN})	A	3.5	2.9
Nominal output power (P_n)	W	63	105
Free-running speed (n_f)	rpm	4400	4500
Free-running current (I_{f0})	A	0.22	0.15
Max. reverse voltage	V DC	35	60
Set value input	V DC	0 ... 10	0 ... 10
Maximum speed	rpm	0 ... 5000	0 ... 5000
Recommended speed control range	rpm	0 ... 4000	0 ... 4000
Function for motor-protection at stall		yes	yes
Torque limitation to M_n		M_n	M_n
Overload protection		yes	yes
Temperature shut-off (via electronics)		110 °C off/on after acknowledgement of "C" hardware enable (< 100 °C)	
Starting torque	mNm	300	500
Rotor moment of inertia (J_R)	kgm ² x10 ⁻⁶	108	108
Thermal resistance (R_{th})	K/W	-	-
Protection class		IP 54*	IP 54*
Ambient temperature range (T_U)	°C	0 ... +40	0 ... +40
Motor mass (m)	kg	0.72	0.72
Order No.		937 4915 600	937 4915 607

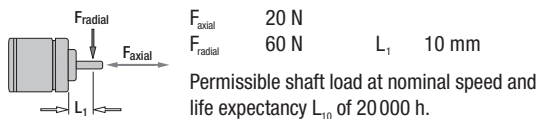

*Classification of protection class refers to installed state with sealing on the flange side.

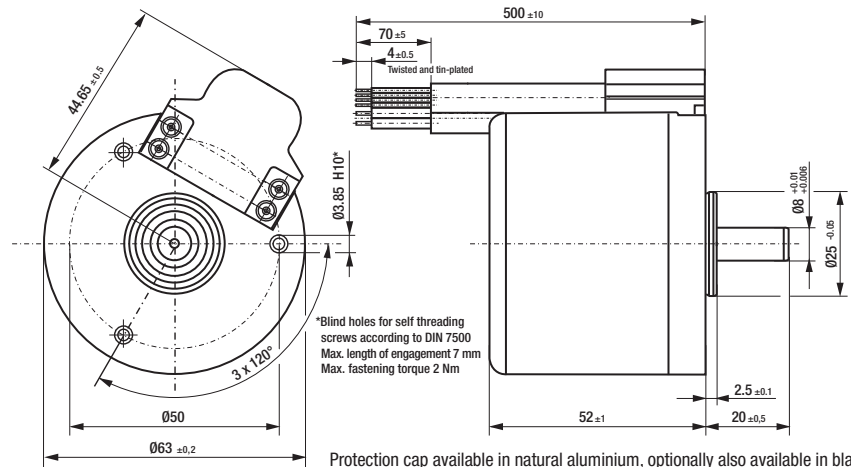
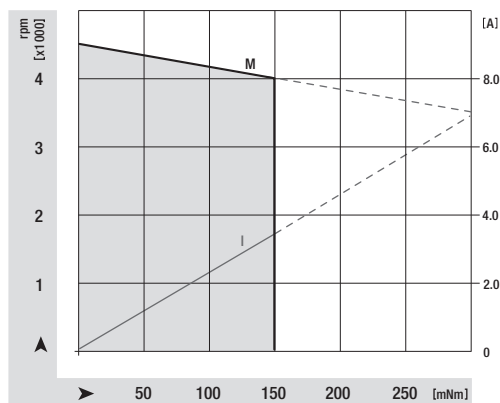

Protection cap available in natural aluminium, optionally also available in black.

Basic functions:

- Closed loop speed control with analogue set value input.
- Control of speed $n = 0$ rpm with holding torque.
- Extended motor dynamics based on short-term peak current with I^2t peak current limitation.
- Torque limitation via analogue set value input (for current limitation).
- Control input for hardware enable for safe switch-on after safety shut-off.
- Separate signal output with TTL level for information on direction of rotation.
- Signal output for status display of the drive via TTL level (drive ready yes/no).
- Separate power supply for motor logic (logic power supply can remain active even when motor is switched off).

Pin configuration

Colour	Function	Description	Connection*
Blue (1,5 mm ²)	Gnd	Supply Ground	Yes
Brown (1,5 mm ²)	+Ub	Logic supply voltage	Yes
Black (1,5 mm ²)	UZK	Supply voltage	Yes
Blue	Gnd	Logic Ground	Yes**
Pink	S1	0 ... 10 V – speed control set value input	Yes
Green	TXD	Communication / programming interface	No
White	RXD	Communication / programming interface	No
Grey-pink	A	Control input A, TTL level	Yes
Violet	B	Control input B, TTL level	Yes
Grey	IST	Actual speed value 1	Yes
Red-blue	F+	Set value input for frequency signal	No
Brown	S2	0 ... 5 V current limitation (torque)	Yes
Black	C	Control input C – hardware enable	Yes
Red	E	Actual speed value 2	Yes
Yellow	D	Status of the drive	Yes

*Connections marked "No" must not be occupied when carrying out basic functions.
 **When using only one power supply the 2 blue leads must be connected to the same Ground.

1. Control inputs

A	B	
0	0	Output stage enabled
0	1	Direction of rotation: counter-clockwise
1	0	Direction of rotation: clockwise
1	1	Brake function*

low (0) 0 to 0.8 V
 high (1) 2.4 to 30 V

*Brake function:
 At motor standstill (0 rpm) the position can be held continuously with nominal torque or short-term with starting torque (I^2t function).

2. Actual speed value output

Version:
 Open collector
 $U_{ext,max} < 36$ V
 $U_{CESAT} = 0.4$ V
 $I_{CMAX} < 10$ mA

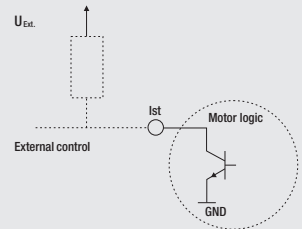
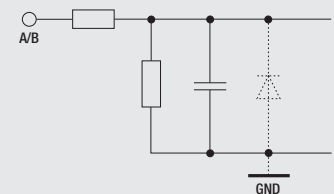
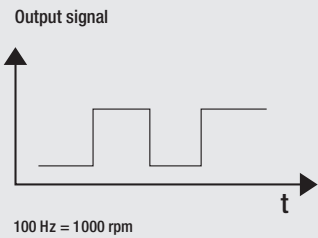

3. Set value input

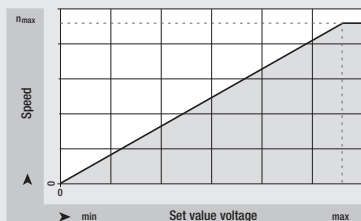

Speed setting for closed loop speed control via set value voltage (interface 0...10 V DC)

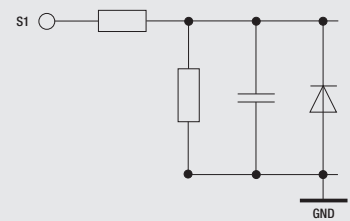

For detailed information please refer to the corresponding specification data sheets. The instructions and safety notes in the operating manual must be kept at all times.

Other options on request:

- Set value input for closed loop speed control operation via set value frequency or PWM signal.
- Input for set value for specifying driving profiles.
- Programming of the I^2t peak current limitation.
- 2-channel encoder signal with up to 100 pulses/revolution via programmable division ratio of the actual value output between both outputs.
- Torque monitor with actual value output optionally either as analogue voltage, frequency or PWM signal.
- Electrically isolated inputs and outputs.
- Control inputs A and B for direction of rotation and brake function with line break detection.
- Position control of the drive.
- RS-485 interface as open communication and programming interface.
- Version with CANopen bus interface (DSP 402).

Even heavy loads now move with finesse.

When requirements call for moving heavy loads in a safe and controlled manner, the torque of the drive alone is frequently not sufficient. Then, gearboxes take over the task of reducing the speed of the drive and increasing the torque accordingly. For dynamic applications, yet another task is added. For these, correctly selected gears ensure suitable adaptation of mass between the drive and the load to be moved. The new VARIODRIVE Compact VDC-3-49.15 is designed in such a way that different gear types in different assembly configurations can be combined with the motor easily. This results in extremely compact and high-performance motor-gear combinations with an extremely wide speed control range.

Gear types

In order to help you making the right selection from the wide variety of possible gear combinations, we have briefly characterised the various types according to their features.

Compactline spur gear units

Spur gears of the Compactline series are built in a robust die-cast zinc housing. With their compact outside dimensions and short design, they are the right choice in every application in which limited installation length is available. With their optimised helical toothing and high overlaps, these gearboxes also feature extremely smooth running and high performance.

Flatline spur gear units

The outstanding features of Flatline spur gears are their extremely short design and high transmissible torques. Optimised helical toothing in the first stage and adapted configurations in the subsequent stages make them real powerhouses. The large distance between the gearbox output shaft and the motor shaft enables any direction of the output shaft, even on both sides.

Performax planetary gears

In contrast to spur gear units, simultaneously revolving planetary gearwheels take over the transmission of the torque in planetary gears. In this way, even high torques can be transmitted within very small diameters with smooth running and little wear. The helically toothed plastic gearwheels of the first stage guarantee high running smoothness. Then, in the second stage, case-hardened gearwheels ensure transmission of the high torques. In the HRL version, especially high radial forces can be absorbed by the cage bearing system of the output shaft.

Noiseless Plus planetary gears

With a precision machined aluminium housing and the slotted helical gearing in the hollow gear, these high-quality gearboxes are the perfect combination of high performance, running smoothness and service life. For applications with increased requirements for the ambient conditions, the available optional version in IP54 type of protection is ideally suited.

EtaCrown angular gears

Compared to worm gears, the most impressive feature of these innovative angular gears is their outstanding efficiency. The reason is the use of crown gear technology. The roll-optimised design of the crown gear stage and the optimised material use also make the gearboxes highly robust, with very smooth running. They are likewise available in an optional IP54 version.



Assembly configurations

Depending on the gear type, the following assembly configurations are available for the VDC-3-49.15 motor:

Gearbox assembly via a NEMA 23 interface

Gearbox assembly via NEMA 23 interface is uncomplicated and is particularly suitable for small quantities or fast sampling requirements. The gearbox can even be mounted by the end customer directly, thanks to the clamping pinion with accurate centering and a square intermediate flange for easy assembly.

Gearbox assembly as direct attachment

For small and medium quantities, various gear types can be assembled using an adapter pinion and round intermediate flange which adds 9 mm to the motor length. In case of medium and high quantities, the intermediate flange can also be replaced by an adapted gearbox base flange, resulting in extremely short and compact motor-gearbox combinations for maximum output with limited installation space.

The table below provides an overview of the possible assembly configurations and reduction ranges for each gear type.

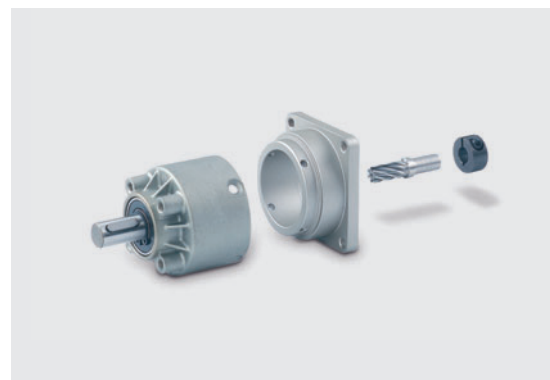

Gearbox versions at a glance

Gear type	Possible gear reduction ratios	
	NEMA 23 interface	Direct assembly
Compactline 91	7.8/9.1/11.1/13.8/18.4/22.0/27.6/41.6/67.3	9.2/18.4/27.6*
Compactline 92	15.47/23.14/31.1/40.1/55.0/70.4/92.3	15.5/18.4/23.1/31.1/40.0
Flatline 85	18.0/27.6/40.3/64.0/101.8	8.2/12.3/27.6/40.3/64.0/101.8
Performax 52	5.0/9.0/21.25/30.0/38.25/54.0	
Performax 63/63 HRL		3.18/5.0/9.0/21.25/30.00
Noiseless Plus 63		4.3/6.0/26.0
EtaCrown 75		4.1/6.7/21.2/33.33

*All 3 ratios assembled without intermediate flange.

The VDC-3-49.15 unites compact dimensions with the highest power density and intelligence. Find out more about the many advantages and possible applications of the new VARIODRIVE Compact motor. Can we contribute to the success of your applications with other ebm-papst products and engineering achievements? Just ask us. We look forward to hearing from you.

ebm-papst
St. Georgen GmbH & Co. KG

Hermann-Papst-Straße 1
D-78112 St. Georgen
Phone +49 7724 81-0
Fax +49 7724 81-1309
info2@de.ebmpapst.com

www.ebmpapst.com