

ECA-Motor

ECA 18.08

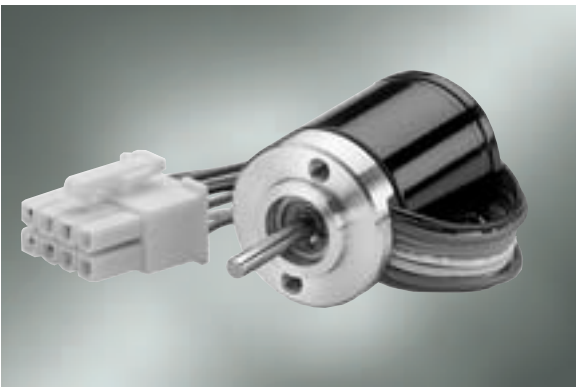

- 3-phase, 6-pulse external rotor motor.
- EC technology.
- Dynamically balanced rotor with 8-pole neodymium magnet.
- Determination of rotor position via 3 Hall sensors.
- Precision ball bearings for long service life and silent running.
- Motor supply and control via external operating electronics.

ebm-papst · St. Georgen

Nominal Data

Type	ECA 18.08	
Nominal voltage (U_{BN})	V DC	24
Nominal speed (n_N)	min^{-1}	6 000
Nominal torque (M_N)	mNm	16
Nominal current (I_{BN})	A	0.9
Nominal output power (P_N)	W	10
Free-running speed (n_L)	min^{-1}	16 000
Free-running current (I_{BL})	A	0.23
Permanent stall torque (M_{BNO})	mNm	14
Permissible eff. stall current, motor lead (I_{N0eff})	A	1.15
Permissible permanent input power at stall (P_{BNO})	W	6.0
Short-term permiss. peak torque (M_{max})	mNm	45
Permiss. peak current, motor lead (I_{max})	A	4.3
Induced voltage (U_{imax})	$\text{V}/1000\text{min}^{-1}$	1.42
Terminal resistance (R_v)	Ω	3.4
Terminal inductance (L_v)	mH	0.76
Rotor moment of inertia (J_R)	$\text{kgm}^2 \times 10^{-6}$	6.20
Thermal resistance (R_{th})	K/W	7.1
Protection class		IP 00
Ambient temperature range (T_u)	$^{\circ}\text{C}$	0 ... +40
Motor mass (m)	kg	0.05
Order No.		933 1808 100

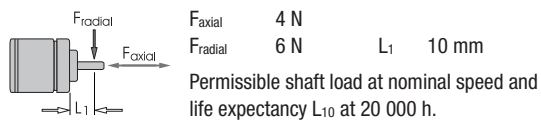

Operating electronics for speed-controlled operation:
DRIVECONTROL VT-A / Order No. 937 2202 001

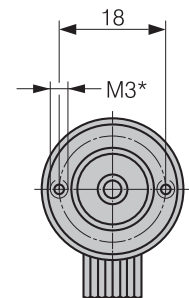
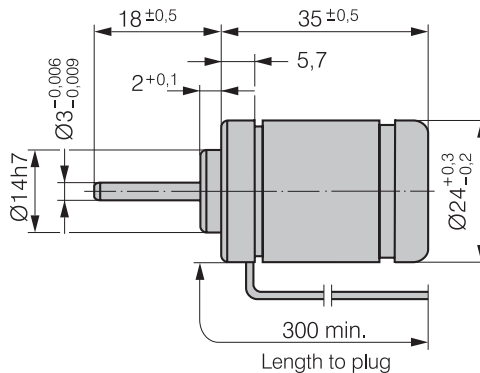
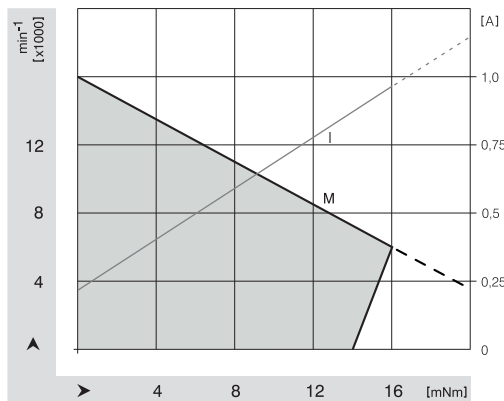

* Screw in depth 6 max.

ECA-Motor

ECA 27.11

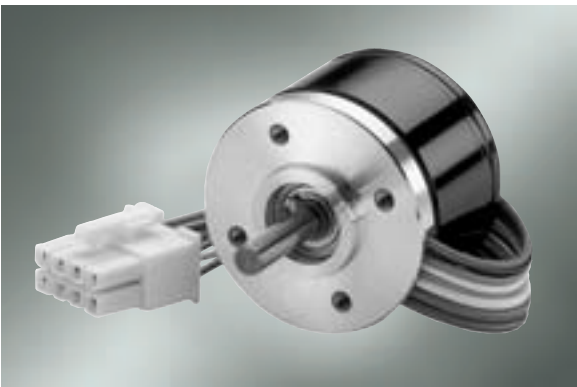

- 3-phase, 6-pulse external rotor motor.
- EC technology.
- Dynamically balanced rotor with 4-pole hard ferrite magnet.
- Determination of rotor position via 3 Hall sensors.
- Precision ball bearings for long service life and silent running.
- Motor supply and control via external operating electronics.

ebm-papst · St. Georgen

Nominal Data

Type	ECA 27.11	
Nominal voltage (U_{BN})	V DC	24
Nominal speed (n_N)	min^{-1}	6 000
Nominal torque (M_N)	mNm	31
Nominal current (I_{BN})	A	1.8
Nominal output power (P_N)	W	20
Free-running speed (n_L)	min^{-1}	18 000
Free-running current (I_{BL})	A	0.36
Permanent stall torque (M_{BNO})	mNm	29
Permissible eff. stall current, motor lead (I_{N0eff})	A	3.0
Permissible permanent input power at stall (P_{BNO})	W	16.5
Short-term permiss. peak torque (M_{max})	mNm	90
Permiss. peak current, motor lead (I_{max})	A	9
Induced voltage (U_{imax})	$\text{V}/1000\text{min}^{-1}$	1.37
Terminal resistance (R_v)	Ω	1.35
Terminal inductance (L_v)	mH	0.72
Rotor moment of inertia (J_R)	$\text{kgm}^2 \times 10^{-6}$	25.5
Thermal resistance (R_{th})	K/W	4.0
Protection class		IP 00
Ambient temperature range (T_u)	$^{\circ}\text{C}$	0 ... +40
Motor mass (m)	kg	0.15
Order No.		933 2711 100

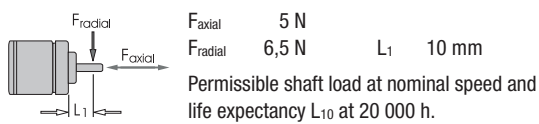

Operating electronics for speed-controlled operation:
DRIVECONTROL VT-A / Order No. 937 2301 001

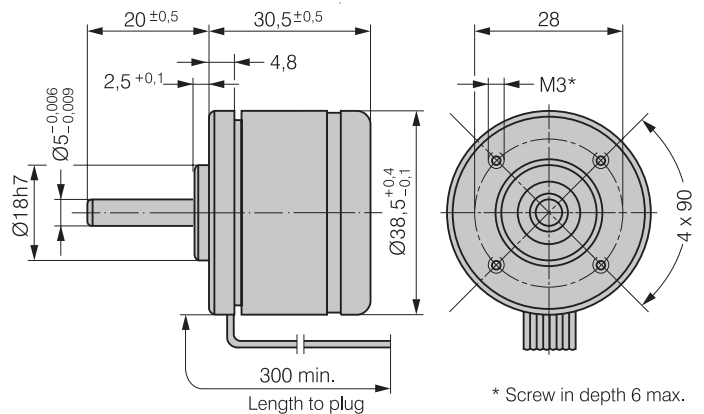
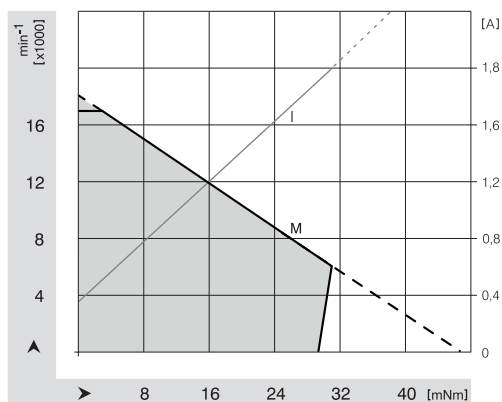

ECA-Motor

ECA 27.25

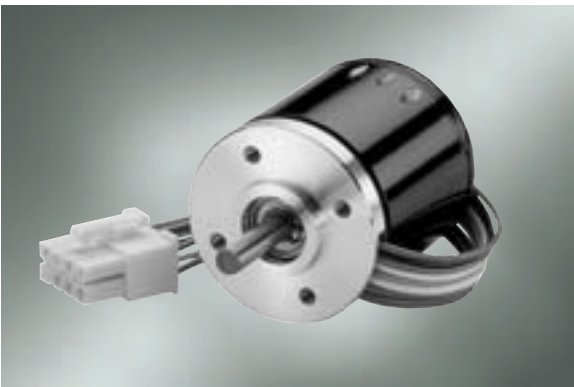

- 3-phase, 6-pulse external rotor motor.
- EC technology.
- Dynamically balanced rotor with 4-pole hard ferrite magnet.
- Determination of rotor position via 3 Hall sensors.
- Precision ball bearings for long service life and silent running.
- Motor supply and control via external operating electronics.

ebm-papst · St. Georgen

Nominal Data

Type	ECA 27.25	
Nominal voltage (U_{BN})	V DC	24
Nominal speed (n_N)	min^{-1}	6 000
Nominal torque (M_N)	mNm	58
Nominal current (I_{BN})	A	3.0
Nominal output power (P_N)	W	36
Free-running speed (n_L)	min^{-1}	17 000
Free-running current (I_{BL})	A	0.6
Permanent stall torque (M_{BNO})	mNm	55
Permissible eff. stall current, motor lead (I_{N0eff})	A	5.0
Permissible permanent input power at stall (P_{BNO})	W	16.5
Short-term permiss. peak torque (M_{max})	mNm	180
Permiss. peak current, motor lead (I_{max})	A	16
Induced voltage (U_{imax})	$\text{V}/1000\text{min}^{-1}$	1.30
Terminal resistance (R_v)	Ω	0.47
Terminal inductance (L_v)	mH	0.3
Rotor moment of inertia (J_R)	$\text{kgm}^2 \times 10^{-6}$	40.7
Thermal resistance (R_{th})	K/W	3.27
Protection class		IP 00
Ambient temperature range (T_u)	$^{\circ}\text{C}$	0 ... +40
Motor mass (m)	kg	0.25
Order No.		933 2725 100

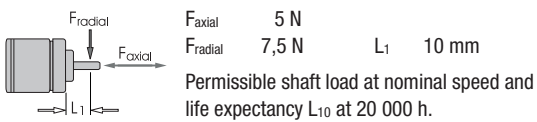

Operating electronics for speed-controlled operation:
DRIVECONTROL VT-A / Order No. 937 2401 001

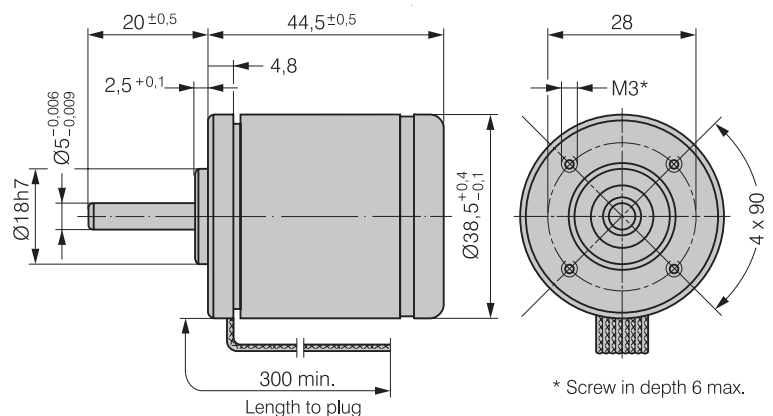
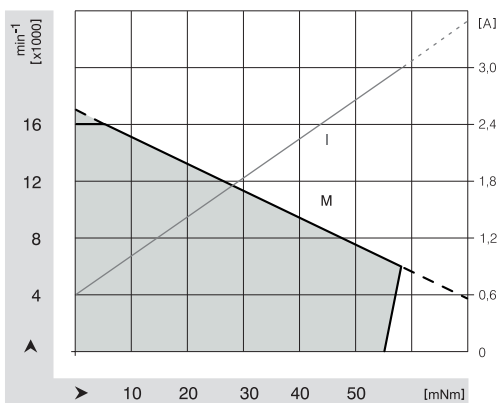

ECA-Motor

ECA 45.11

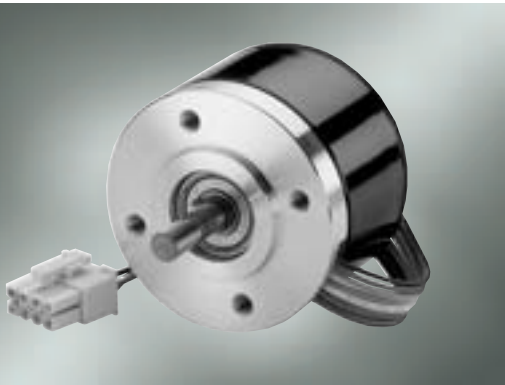

- 3-phase, 6-pulse external rotor motor.
- EC technology.
- Dynamically balanced rotor with 4-pole hard ferrite magnet.
- Determination of rotor position via 3 Hall sensors.
- Precision ball bearings for long service life and silent running.
- Motor supply and control via external operating electronics.

ebm-papst · St. Georgen

Nominal Data

Type	ECA 45.11	
Nominal voltage (U_{BN})	V DC	24
Nominal speed (n_N)	min ⁻¹	3 000
Nominal torque (M_N)	mNm	120
Nominal current (I_{BN})	A	3.2
Nominal output power (P_N)	W	35
Free-running speed (n_L)	min ⁻¹	8 250
Free-running current (I_{BL})	A	0.35
Permanent stall torque (M_{BNO})	mNm	100
Permissible eff. stall current, motor lead (I_{N0eff})	A	4.2
Permissible permanent input power at stall (P_{BNO})	W	18.5
Short-term permiss. peak torque (M_{max})	mNm	340
Permiss. peak current, motor lead (I_{max})	A	14
Induced voltage (U_{imax})	V/1000min ⁻¹	3.04
Terminal resistance (R_v)	Ω	0.76
Terminal inductance (L_v)	mH	0.69
Rotor moment of inertia (J_R)	kgm ² x10 ⁻⁶	164.3
Thermal resistance (R_{th})	K/W	2.52
Protection class		IP 00
Ambient temperature range (T_u)	°C	0 ... +40
Motor mass (m)	kg	0.50
Order No.		933 4511 101

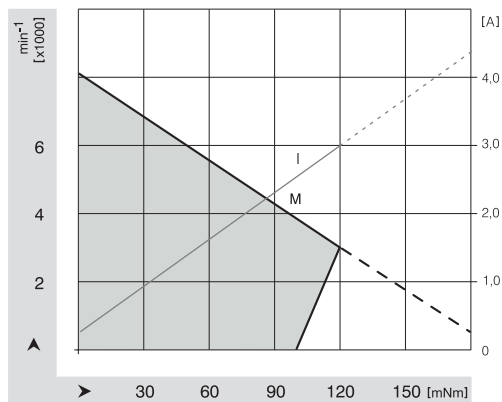
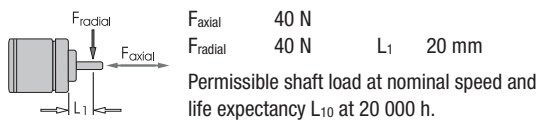

Operating electronics for speed-controlled operation:
DRIVECONTROL VT-A / Order No. 937 2501 001

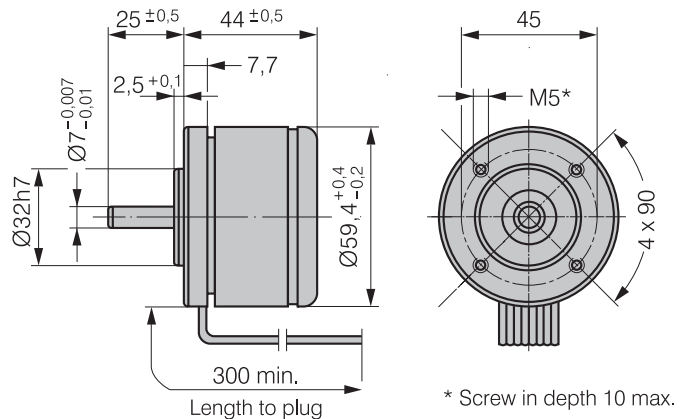

ECA-Motor

ECA 45.30

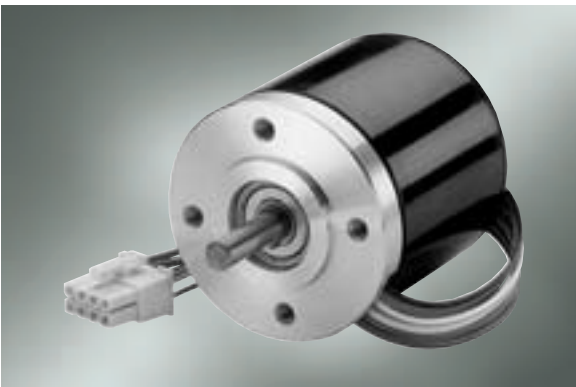

- 3-phase, 6-pulse external rotor motor.
- EC technology.
- Dynamically balanced rotor with 4-pole hard ferrite magnet.
- Determination of rotor position via 3 Hall sensors.
- Precision ball bearings for long service life and silent running.
- Motor supply and control via external operating electronics.

ebm-papst · St. Georgen

Nominal Data

Type	ECA 45.30	
Nominal voltage (U_{BN})	V DC	36
Nominal speed (n_N)	min^{-1}	6 000
Nominal torque (M_N)	mNm	300
Nominal current (I_{BN})	A	8.0
Nominal output power (P_N)	W	200
Free-running speed (n_L)	min^{-1}	12 000
Free-running current (I_{BL})	A	0.65
Permanent stall torque (M_{BNO})	mNm	280
Permissible eff. stall current, motor lead (I_{N0eff})	A	10
Permissible permanent input power at stall (P_{BNO})	W	35
Short-term permiss. peak torque (M_{max})	mNm	1 000
Permiss. peak current, motor lead (I_{max})	A	40
Induced voltage (U_{imax})	$\text{V}/1000\text{min}^{-1}$	2.99
Terminal resistance (R_v)	Ω	0.23
Terminal inductance (L_v)	mH	0.33
Rotor moment of inertia (J_R)	$\text{kgm}^2 \times 10^{-6}$	266.5
Thermal resistance (R_{th})	K/W	0.99
Protection class		IP 00
Ambient temperature range (T_u)	$^{\circ}\text{C}$	0 ... +40
Motor mass (m)	kg	0.75
Order No.		933 4530 101

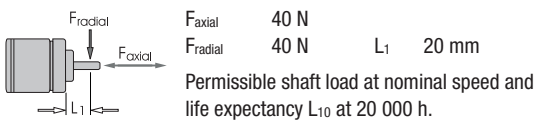

Operating electronics for speed-controlled operation:

DRIVECONTROL VT-D / Order No. 937 6210 001

Operation at 24 V with DRIVECONTROL VT-A with reduced output power possible.

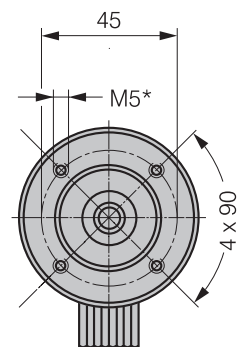
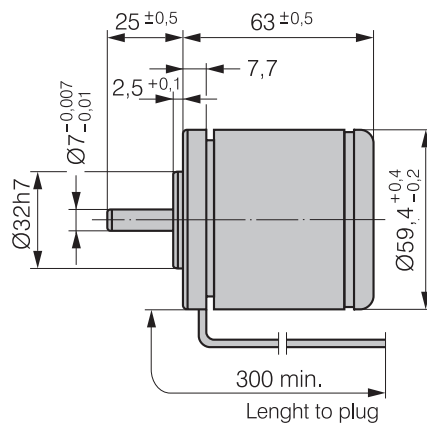
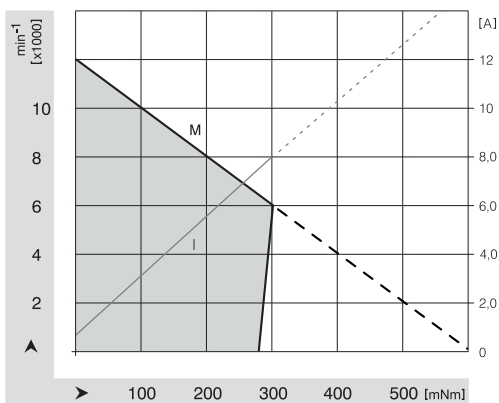

* Screw in depth 10 max.

ECA-Motor

ECA 70.10

- 3-phase, 6-pulse external rotor motor.
- EC technology.
- Dynamically balanced rotor with 4-pole hard ferrite magnet.
- Determination of rotor position via 3 Hall sensors.
- Precision ball bearings for long service life and silent running.
- Motor supply and control via external operating electronics.

ebm-papst · St. Georgen

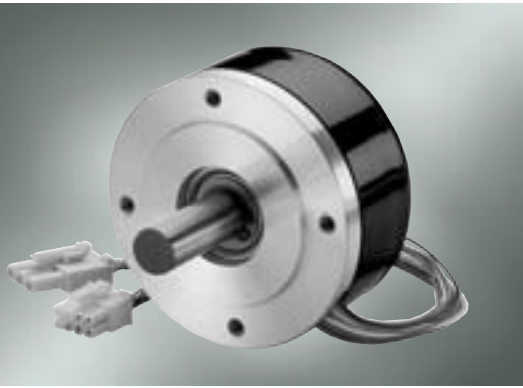

Nominal Data

Type		ECA 70.10
Nominal voltage (U_{BN})	V DC	48
Nominal speed (n_N)	min ⁻¹	5 000
Nominal torque (M_N)	mNm	370
Nominal current (I_{BN})	A	5.6
Nominal output power (P_N)	W	195
Free-running speed (n_L)	min ⁻¹	6 400
Free-running current (I_{BL})	A	0.59
Permanent stall torque (M_{BNO})	mNm	300
Permissible eff. stall current, motor lead (I_{N0eff})	A	5.0
Permissible permanent input power at stall (P_{BNO})	W	30.5
Short-term permiss. peak torque (M_{max})	mNm	900
Permiss. peak current, motor lead (I_{max})	A	14
Induced voltage (U_{imax})	V/1000min ⁻¹	8.15
Terminal resistance (R_v)	Ω	0.85
Terminal inductance (L_v)	mH	1.77
Rotor moment of inertia (J_R)	kgm ² x10 ⁻⁶	942.1
Thermal resistance (R_{th})	K/W	1.19
Protection class		IP 00
Ambient temperature range (T_u)	°C	0 ... +40
Motor mass (m)	kg	1.20
Order No.		933 7010 100

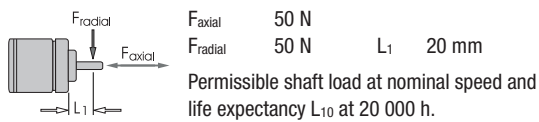

Operating electronics:

DRIVECONTROL VT-E / Order No. 992 0490 000

Adapted operating electronics DRIVECONTROL VT-D on request.

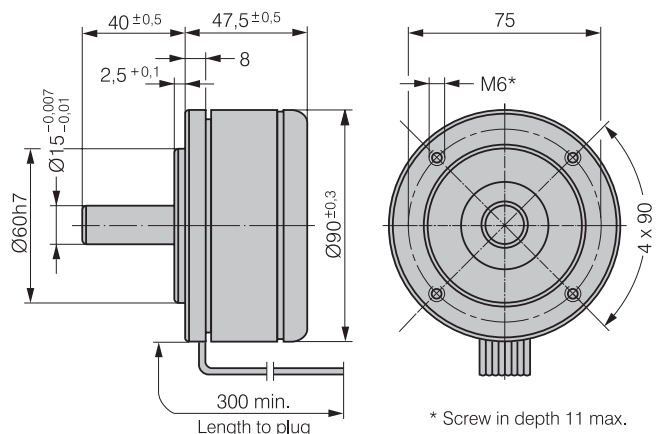
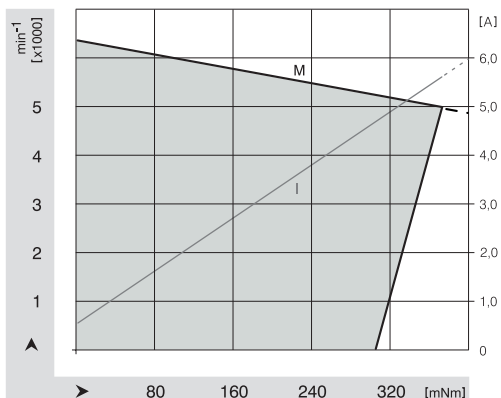

ECA-Motor

ECA 70.32



- 3-phase, 6-pulse external rotor motor.
- EC technology.
- Dynamically balanced rotor with 4-pole hard ferrite magnet.
- Determination of rotor position via 3 Hall sensors.
- Precision ball bearings for long service life and silent running.
- Motor supply and control via external operating electronics.

ebm-papst · St. Georgen

Nominal Data

Type	ECA 70.32	
Nominal voltage (U_{BN})	V DC	48
Nominal speed (n_N)	min^{-1}	4 350
Nominal torque (M_N)	mNm	690
Nominal current (I_{BN})	A	8.5
Nominal output power (P_N)	W	315
Free-running speed (n_L)	min^{-1}	5 200
Free-running current (I_{BL})	A	0.65
Permanent stall torque (M_{BNO})	mNm	660
Permissible eff. stall current, motor lead (I_{N0eff})	A	9.0
Permissible permanent input power at stall (P_{BNO})	W	57.0
Short-term permiss. peak torque (M_{max})	mNm	2000
Permiss. peak current, motor lead (I_{max})	A	28
Induced voltage (U_{imax})	$\text{V}/1000\text{min}^{-1}$	9.3
Terminal resistance (R_v)	Ω	0.49
Terminal inductance (L_v)	mH	1.2
Rotor moment of inertia (J_R)	$\text{kgm}^2 \times 10^{-6}$	1459
Thermal resistance (R_{th})	K/W	0.98
Protection class		IP 00
Ambient temperature range (T_u)	$^{\circ}\text{C}$	0 ... +40
Motor mass (m)	kg	1.80
Order No.		933 7032 100

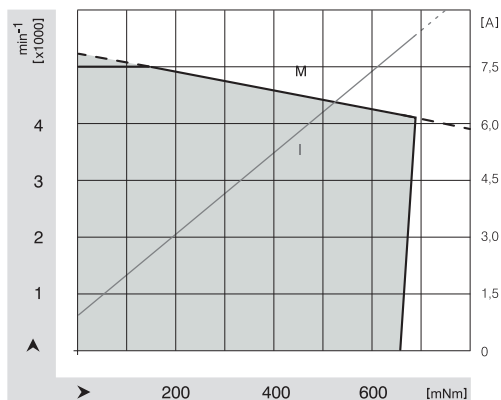
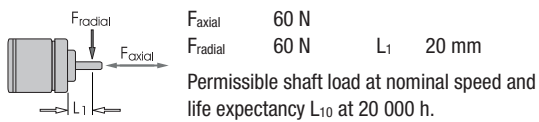

Operating electronics:

DRIVECONTROL VT-E / Order No. 992 0490 000

Adapted operating electronics DRIVECONTROL VT-D on request.

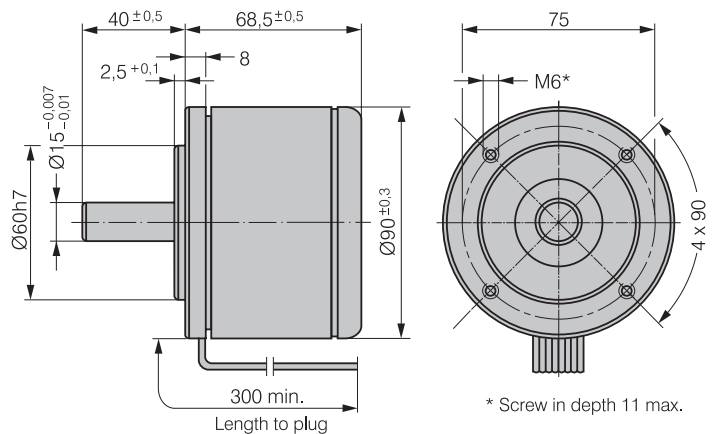

ECA-Motor

ECA 70.50



- 3-phase, 6-pulse external rotor motor.
- EC technology.
- Dynamically balanced rotor with 4-pole hard ferrite magnet.
- Determination of rotor position via 3 Hall sensors.
- Precision ball bearings for long service life and silent running.
- Motor supply and control via external operating electronics.

ebm-papst · St. Georgen

Nominal Data

Type		ECA 70.50
Nominal voltage (U_{BN})	V DC	48
Nominal speed (n_N)	min^{-1}	4 200
Nominal torque (M_N)	mNm	725
Nominal current (I_{BN})	A	8.5
Nominal output power (P_N)	W	320
Free-running speed (n_L)	min^{-1}	5 100
Free-running current (I_{BL})	A	0.66
Permanent stall torque (M_{BNO})	mNm	650
Permissible eff. stall current, motor lead (I_{N0eff})	A	7.5
Permissible permanent input power at stall (P_{BNO})	W	30.5
Short-term permiss. peak torque (M_{max})	mNm	1 900
Permiss. peak current, motor lead (I_{max})	A	27
Induced voltage (U_{imax})	$\text{V}/1000\text{min}^{-1}$	9.78
Terminal resistance (R_v)	Ω	0.38
Terminal inductance (L_v)	mH	0.92
Rotor moment of inertia (J_R)	$\text{kgm}^2 \times 10^{-6}$	1947
Thermal resistance (R_{th})	K/W	1.16
Protection class		IP 00
Ambient temperature range (T_u)	$^{\circ}\text{C}$	0 ... +40
Motor mass (m)	kg	2.40
Order No.		933 7050 100

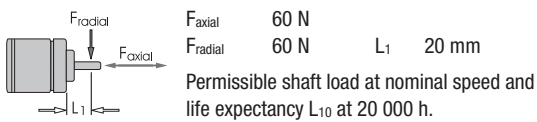

Operating electronics:

DRIVECONTROL VT-E / Order No. 992 0490 000
 Adapted operating electronics DRIVECONTROL VT-D on request.

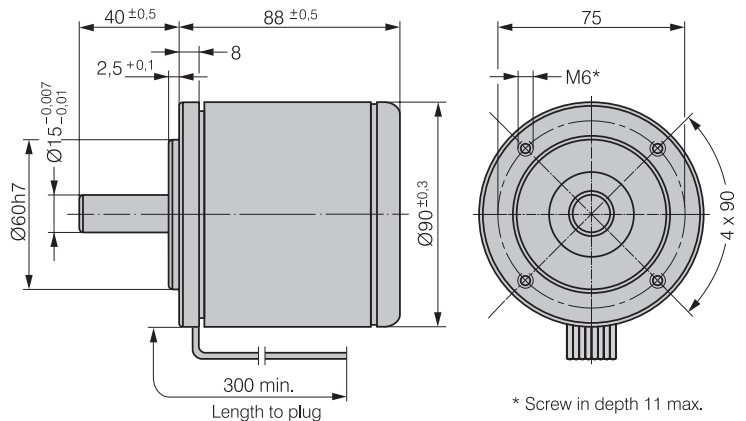
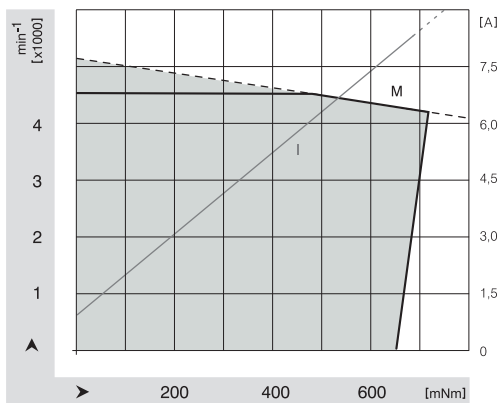

ECA-Motor

ECgear 27.XX

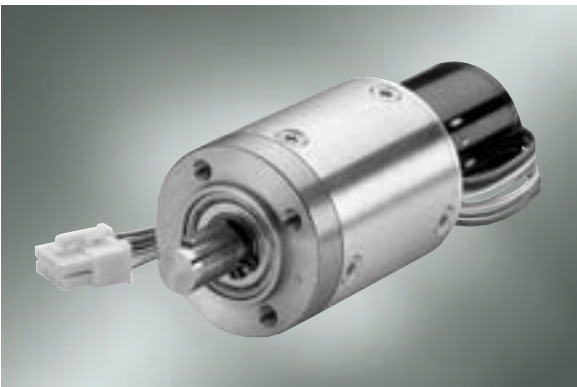

- 3-phase, brushless external rotor motor for gear applications.
- Combined with 1 to 3-stage planetary gears for high torque requirements, high reduction ratio and long service life.
- Adhesive grease for maintenance-free continuous operation.
- Steel gear body.
- Precision ball bearings.
- Reversible direction of rotation.

ebm-papst · St. Georgen

Nominal Data	Nominal voltage	Nominal current	Gear ratio	Nominal torque	Speed range	Service life	Mass	Order No.
Type	A	i	Nm	min ⁻¹	h	kg		
ECgear 27.11-3	24	1.35	400 : 1	7.4	1 ... 7	—	1.10	936 2711 300
ECgear 27.25-1	24	2	4.5 : 1	0.22	110 ... 800	—	0.95	936 2725 100
ECgear 27.25-2	24	2	20 : 1	0.82	25 ... 180	—	1.10	936 2725 200
ECgear 27.25-3	24	2	91 : 1	3.2	5.5 ... 40	—	1.20	936 2725 300

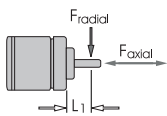

F_{axial} 500 N
 F_{radial} 350 N
 L_1 13 mm
 Permissible shaft load at nominal speed

Operating electronics for speed-controlled operation:

for Order No. 936 2711 XXX = DRIVECONTROL VT-A / Order No. 937 2301 002
 for Order No. 936 2725 XXX = DRIVECONTROL VT-A / Order No. 937 2401 002

Type	27.11-3	27.25-1	27.25-2	27.25-3
L_1	78.4±0.8	47.9±0.8	63.4±0.8	78.4±0.8
L_2	111 ±1.5	94.5 ±1.5	110 ±1.5	125 ±1.5

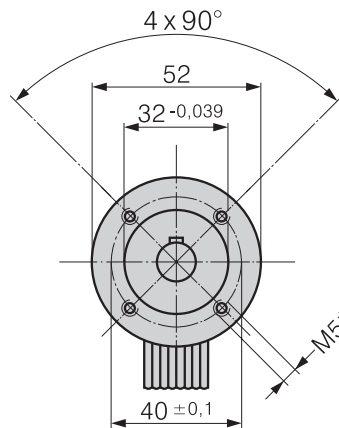
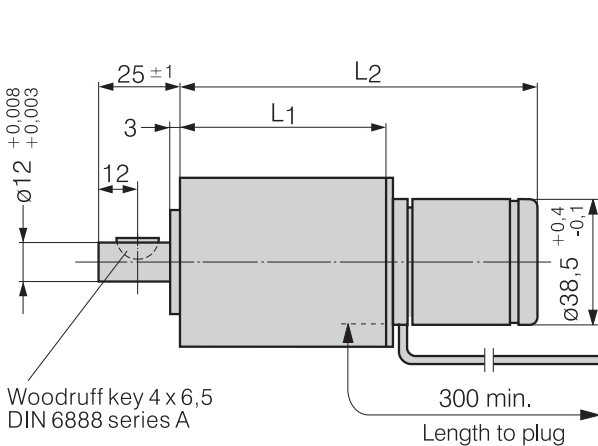

* Screw in depth 7,5 max.

ECA-Motor

ECgear 45.30



- 3-phase, brushless external rotor motor for gear applications.
- Combined with 1 to 3-stage planetary gears for high torque requirements, high reduction ratio and long service life.
- Adhesive grease for maintenance-free continuous operation.
- Steel gear body.
- Precision ball bearings.
- Reversible direction of rotation.

ebm-papst · St. Georgen

Nominal Data	Nominal voltage	Nominal current	Gear ratio	Nominal torque	Speed range	Service life	Mass	Order No.
Type		A	i	Nm	min ⁻¹	h	kg	
ECgear 45.30-1	36	5.5	4.5 : 1	1.2	110 ... 800	—	0.25	936 4530 101
ECgear 45.30-2	36	5.4	36 : 1	8.0	14 ... 100	—	1.40	936 4530 201
ECgear 45.30-3	36	5.4	127 : 1	24.0	4 ... 28.5	—	1.55	936 4530 301

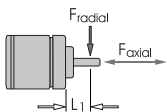

F_{axial} 500 N
 F_{radial} 350 N
 L_1 13 mm
 Permissible shaft load at nominal speed

Operating electronics for speed-controlled operation:

Adapted operating electronics DRIVECONTROL VT-D on request.
 Operation at 24 V with DRIVECONTROL VT-A with reduced power possible.

Type	45.30-1	45.30-2	45.30-3
L_1	47.9 ± 0.8	63.4 ± 0.8	78.4 ± 0.8
L_2	94.5 ± 1.5	110 ± 1.5	125 ± 1.5

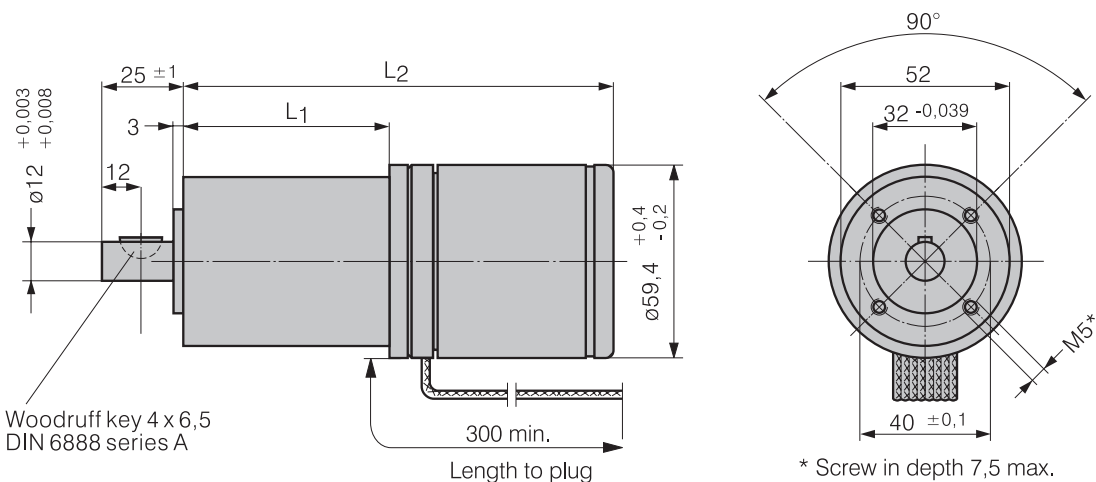

ECA-Motor

ECA 70.XX with speed sensor



- Magnetic tachometer track on faceside.
- 100 magnet pole (50 pole pairs) for ECA 70.XX.
- Evaluation of magnetic tachometer track via 2 differential Hall ICs for detecting direction of rotation and position when using corresponding positioning control electronics.
- High resolution speed information for reliable control of lower speeds (e.g. with DRIVECONTROL VT-E).
- No additional mechanical elements required.
- Speed range for tachometer signal frequencies $f_r < 10$ kHz (e.g. for ECA 70.XX to approx. 6.000 r.p.m.).
- For smaller ECA sizes optional at adequate volumes.

ebm-papst · St. Georgen

Hall-IC

Hall-Specification: Hall-IC 300UA-E
 Supply voltage range:
 $V_{CC} = 4.5 \dots 24$ V DC
 Output: Open Collector
 Max. Output current: $I_o \leq 20$ mA

Pulse frequency for clockwise direction of rotation

