

Sensor fans

More comfort in
climate control

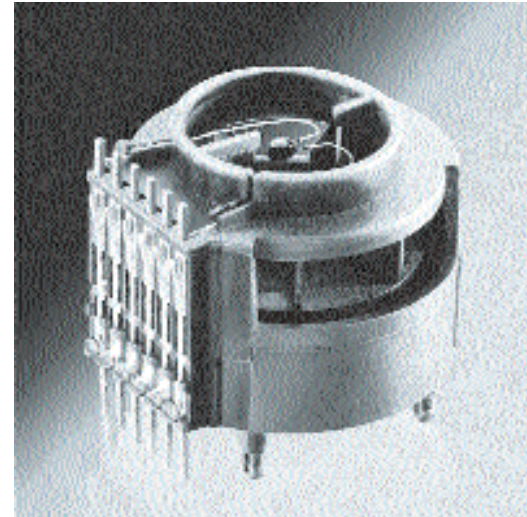

Sensor fans by ebm-papst:
the climate control experts in automobiles

ebmpapst

ebm-papst: your innovative partner in climate sensor technology

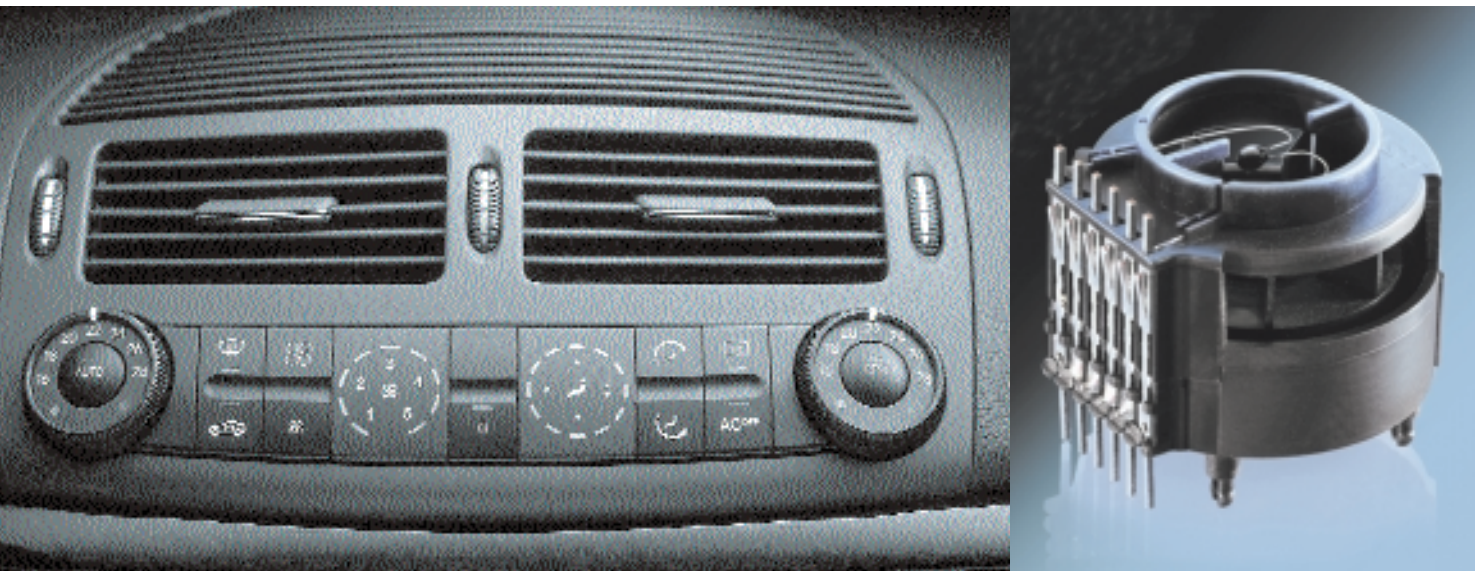

The S 2000 sensor fan is now in its third generation and is the reference product in vehicle climate sensor technology in terms of efficiency, comfort, flexibility and durability.

Automatic climate control: soon to be standard in virtually every vehicle

Air conditioning comfort is increasingly becoming a vital issue when buying a car, which explains why the number of vehicles with automatic climate control is growing rapidly. For drivers who want the best it's all about the extra comfort they appreciate, for us it requires fast response temperature sensors to control air conditioning systems. The fast growing variety of air conditioning system models also means an ever-increasing number of individual and tailored solutions producing fast, tried and trusted solutions based on platform developments, coupled with considerable engineering experience is needed.

Our sensor fans create a better climate in your car

Whether it's hot or cold, wet or dusty: air-conditioning provides the kind of comfort a driver expects. Automatic climate control should be as reliable and responsive as possible. Our compact sensor fans with integrated or external measuring sensors provide the economic, effective and convenient solution.

They're economical because their modular design means they can be fitted in absolutely any air-conditioning unit and in virtually any position in the vehicle – plus we can mass produce even the most custom-made solutions.

They're effective because our sensor fans supply your air-conditioning systems with accurate data in all temperatures in real time.

Passengers are comfortable because our fans operate virtually noise-free and nothing will put them off their stride in any operating situation.

How to make sure you get the right results

Our wide range of individually modifiable sensor fans enables you to regulate air conditioning systems quickly and safely. That's why ebm-papst is a company who you can partner with confidence.

A brilliant idea: active ventilation with a temperature sensor

Before you can regulate any temperature you have to measure the ambient temperature first. The faster and more accurately you can do this, the more effectively the air conditioning system will work. However, temperatures in the passenger compartment fluctuate widely. They are completely different at the back of the vehicle, for example, than for the driver or close to fan openings – so a “neutral” measurement set-up is required. Today the accepted method of determining temperatures is by using temperature sensors (NTC resistors). If these are specifically “force-ventilated” with ambient air. They record its average value while taking into account local influences such as strong solar radiation or open windows.

The principle of active ventilation prevents false measurements, providing the temperature readings instantaneously and allowing any air-conditioning system to work efficiently.

The latest trend: multi-point temperature sensing

For an more accurate temperature measurement, in vehicles with large passenger compartments or with custom air-conditioning, the latest trend is to mount several sensor fans together in a control system: standalone versions with integrated electronic power can be mounted in the roof or in other positions in the car.

For even more accurate measurements, the latest trend is to accommodate several sensor fans in a vehicle. As well as being positioned directly in the air-conditioning control unit they can be fitted as a standalone version (with integrated electronic power), for example, in the ceiling light, at the back of the car or in the center console: This means hot and cold spots inside the vehicle can be sensed effectively and managed.

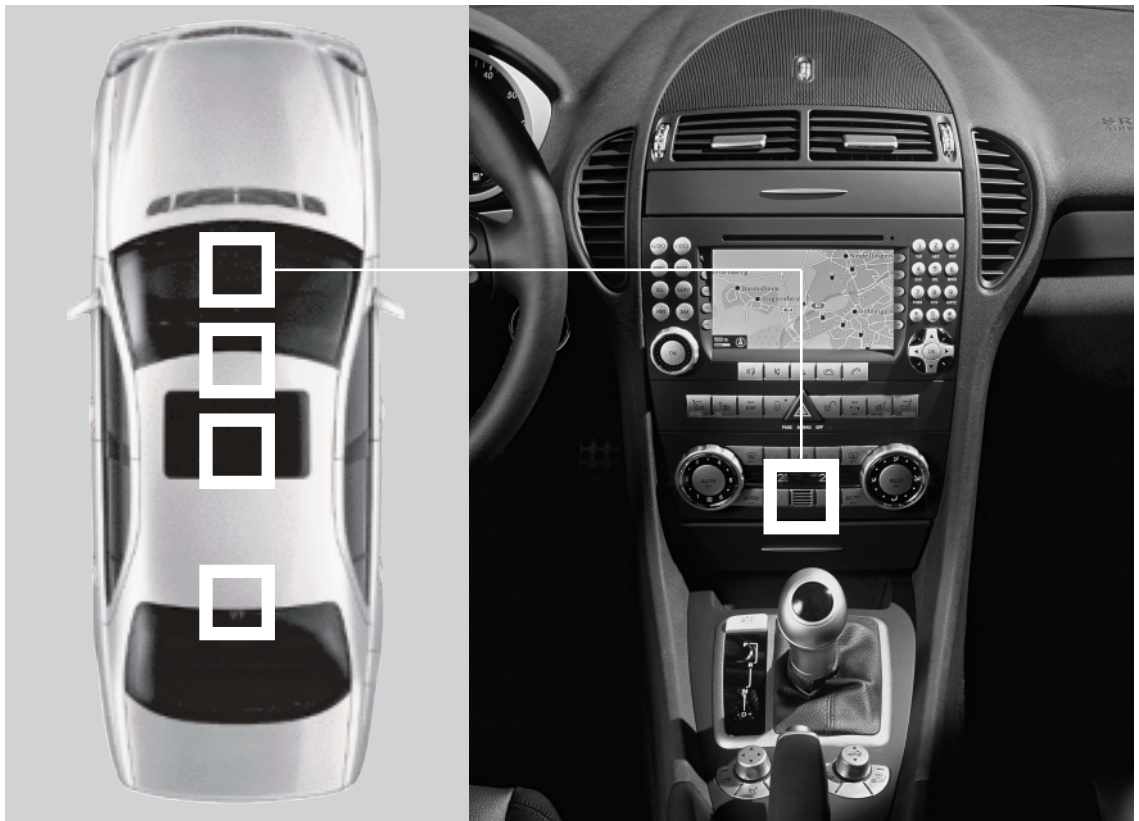

Our sensor fans: a technology that should be part of every air conditioning system

Sensor fans are among the most complex mechatronic products

The high-density packaging of electronic and mechanical components, their miniaturized power systems, their aerodynamic flow characteristics and not least the quality expected by the automobile industry require the most sophisticated industrial engineering.

Innovation significant for the right application: from development to production to service

The modular component system of our fans makes highly automated production methods possible. It means we can make sensor fans to meet specific client needs even in large quantities – and with maximum precision.

Effective quality planning and preventative quality control at all stages of manufacturing (including zero defect programs) are required for the development and production of automotive-ready products. In order to ensure they operate effectively, sensing has to be carried out on numerous levels: for example, the simulation of extreme temperatures in a climate test cabinet, vibration and shock tests, frequency analyses of the air and structure-borne sound, lubrication technology tests and even determination of the performance curve of a sensor fan. Overall we conduct painstaking analysis to ensure everything performs well under tough automotive conditions.



Our “no compromise” attitude towards quality management covers all stages of the process

This includes advising the customers, choosing the materials, selecting certified suppliers, manufacturing the product and supplying them to be defect free. For more than 15 years ebm-papst has been the leading provider in sensor technology and a sought after development partner. Around 35 million of these sensor fans have been installed in vehicles of virtually every make since then. That's convincing evidence of the exceptional road capability of our product.

Versatile technology that's so effective

They're compact, effective and tried and trusted over many years. Because of their versatility, reliability and intelligence in regulating air-conditioning units, ebm-papst sensor fans are the original and best. Our sensor fans are designed to integrate perfectly into any system for the complete lifetime of the car.

Long life and quiet operation in miniature

Sensor fan power is provided by an electronically commutated external rotor motor. This type of motor has some outstanding benefits. Our EC motor avoids the pitfalls associated with mechanical brush commutation such as the commutation device wear out, brush friction, dust build up due to abrasion, noise, start up problems due to commutator corrosion plus the high frequency interference produced by spark formation.

However, a decisive factor in the long life and operation of the fan is the result of the quality of the bearing system. Sensor fans are equipped with an ebm-papst Sintec® bearing, a slide bearing system, which has proven to be ideal for automotive use with its low noise levels and insensitivity to shocks.

The car industry demands so much from our sensor fans:

- The noise emissions for this kind of sensor fan – with a microphone placed 10 cm away – have to be under 25 dB(A) in free blowing operation.
- The electronically commutated motor has to function with total reliability within a widely defined temperature range: for products of this kind, it means between -40 and +95 degrees.
- Sensor fans have to be compatible with the vehicle electrical system and comply with EMV standards.
- Our fans meet or exceed the automobile industry lifetime requirements for their vehicles.
- Process monitoring of production and traceability by data code for each individual.

Compact:

EC motors are distinguished by their compact overall size. Commutating is done with two coils: one drive coil and one sensor coil to determine the rotor position. Speed and functionality can be monitored via the on-board computer.

Fit and forget:

Maintenance-free ebm-papst Sintec slide bearing system is designed for maximum durability and minimal noise. Insensitive to vibration and shocks.

Highly integrated:

Power via the compact external claw pole motor with a stator diameter of only 17mm. A magnetic bias secures the rotor and compensates for even violent vibrations and shocks.

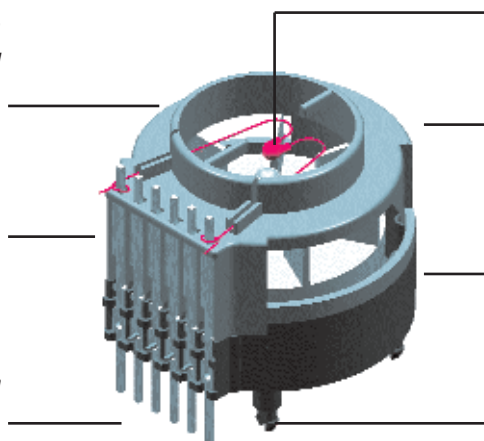

Climate zone:

The temperature sensors are designed individually and based on vehicle type.

A versatile concept:

Fan housing and insulation can be adjusted to the aerodynamic and application specific requirements.

Effective:

Compact construction with an aerodynamically radial wheel, is optimized for high air throughput and high generation of pressure.

Easy to assemble:

Like conventional electronic components, sensor fans are simply snapped on to the circuit board and soldered. Alternatively they can be positioned and connected anywhere in the vehicle.

The system components: maximum flexibility for any situation

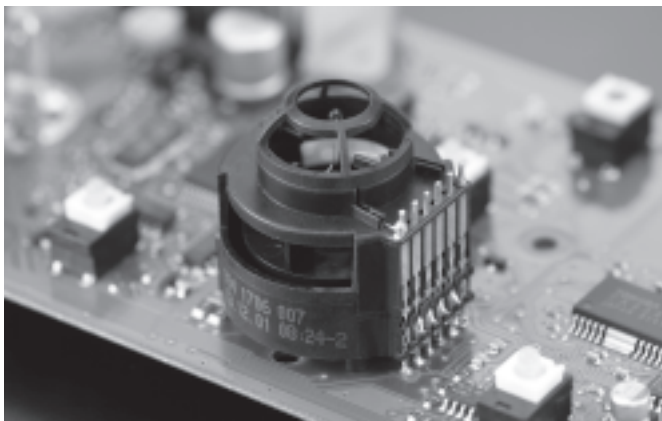

Flexibility of superior engineering

The motor housing provides a wide variety of different connections. The basic modular structure enables various combinations of individual components and therefore any choice of assembly position you need – on the inlet manifold side, on the back or on the side. Initially you have the option of a snap on or screw connection. Contacting can also be designed for individual customers: both tin-plated solder-on contacts and plug-in gold plated contacts are available.

Plug-in sensor fans for board mounting

Version with sensor

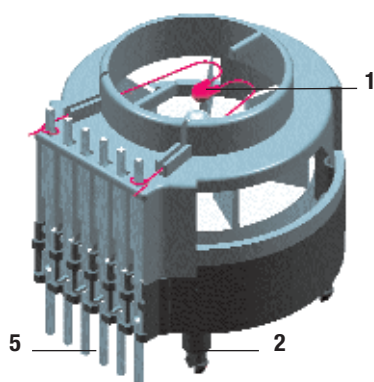

Version without sensor

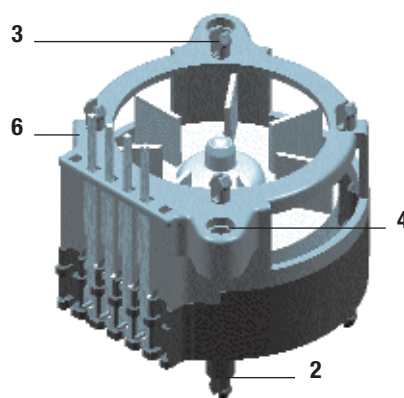

- 1 With temperature sensor
- 2 Clip-on flange side
- 3 Clip on housing side
- 4 Screw attachment housing side
- 5 Contacting flange side
- 6 Contacting housing side

Special housing



Soft attachment

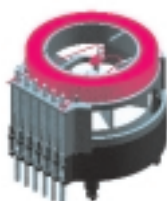

With mounting adapter



With protective grating

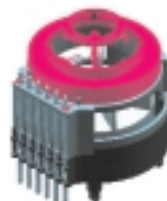

With protective grating

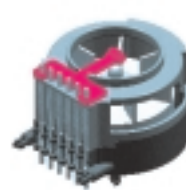

Success through versatility

At ebm-papst you have a partner who understands your requirements. Because we don't just develop and build sensor fans: The major benefit is that you have an intelligent as well as modular system, which can be adapted to your unique requirements.

Flexibility

It is possible to choose between sensor fans with an external drive or internal drive with integrated electronic power. As the standard version for installation in air-conditioning panels you should consider sensor fans without their own electronic motor, as these can be mounted on the existing printed circuit board of the control unit. In this case, a difference is also made between fans with a temperature sensor that is already integrated or an external one made to the customer's specifications.

Sensor fans with an integrated electronic motor and integrated sensor are a complete module, which is ready to fit in any part of the vehicle. One version is available as a control panel with external electronic operation as well as a standalone fan, which can be mounted in the automobile.

Stand-alone sensor fans with integrated electronic operation

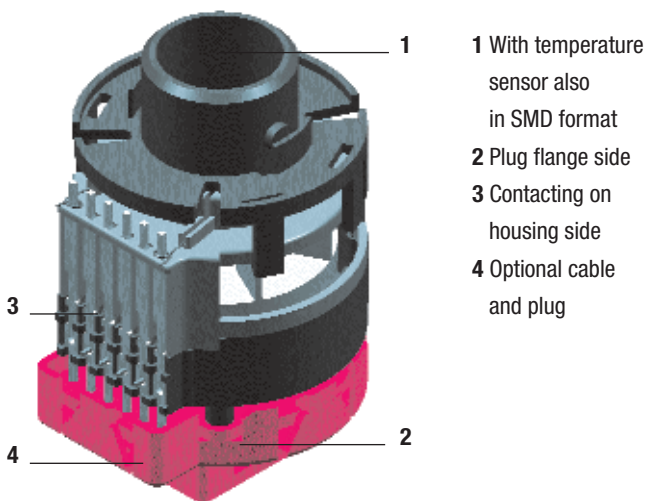

Technical data	
Power	Electronically commuted claw pole external rotor motor
Temperature sensor	NTC resistance, integrated or external
Bearing system	Sintec® slide bearing system
Voltage range	8 ... 16 V DC
Rated voltage	13 V DC
Current consumption	≤ 50 mA
Rated speed	2700 rpm
Max. airflow	18 l/min
Operating temperature	-40 ... +95 °C
Storage temperature	-40 ... +100 °C
Weight	14-21 g
Dimensions	Ø 30 x 25 mm With integrated electronics Ø 30 x 40 mm

Find out more:

- *Corporate profile / facts and figures*
- *Automotive brochure*

ebm-papst has the world's most advanced motors and fans. Why not discuss your requirements with us? We look forward to hearing from you.

ebm-papst
St. Georgen GmbH & Co. KG

Hermann-Papst-Straße 1
D-78112 St. Georgen
Phone +49 (0) 7724 / 81-0
Fax +49 (0) 7724 / 81-1309
info2@de.ebmpapst.com

www.ebmpapst.com/de

ebmpapst