

Only available for OEM

DC Sensor Blower

ebmpapst

S 2000 Type 006



Stand-alone small sensor blower with integrated operating electronics for active ventilation of temperature sensors for automatic temperature control of air conditioning systems in cars. The active ventilation avoids mismeasurements due to irradiation of various heat sources. Significant reduced overall size due to the new motor technique of an external rotor motor on pinch pole basis.

- Version with temperature sensor (NTC resistor $10\text{ k}\Omega \pm 3,5\%$ at $25\text{ }^\circ\text{C}$; details on request)
- Modular design with mechanical fixing and electrical connection possibility at blower suck and back side
- Plug-in version (without drive-electronics)
- Sinter-Bearing-System
- Quality Management ISO/TS 16949

ebm-papst • St. Georgen

Nominal data	Voltage Range	Nominal Voltage	Nominal Current (free air)	Nominal Speed (free air)	Max. Flow Rate (free air)	Air flow	Operating Temp. (sensor blower without electronics)	Storage Temp.	Service life (at $23\text{ }^\circ\text{C}$ environment temp.)	Noise* (free air)	Mass
Type	V DC	V DC	mA	rpm	$\times 10^{-3}\text{m}^3/\text{min}$	CFM	$^\circ\text{C}$	$^\circ\text{C}$	h	dB (A)	g
934 1706 006	8...16	13	<50	2 650	18	0.64	-40...+95	-40...+100	5 000	<26	14

* Measured at free air delivery. Microphone distance 10 cm. Sensor blower assembled freerunning in elastic bands.
All data are based on the operation with the commutation electronics indicated on the reverse side (average values at nominal voltage).

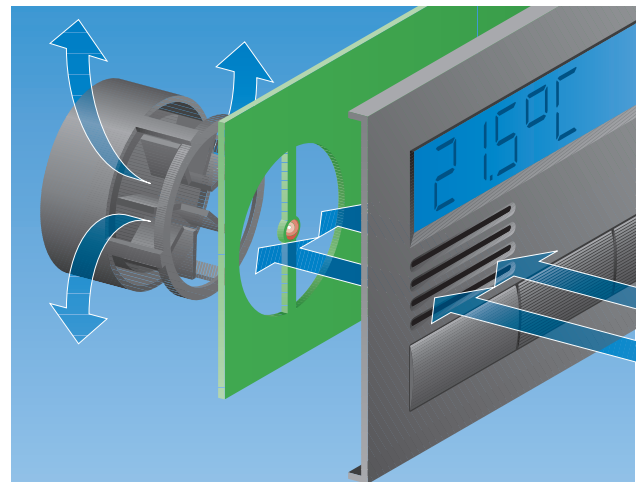
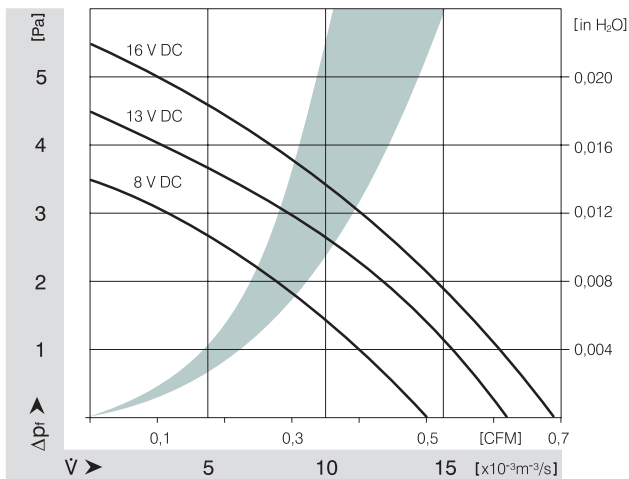

Wiring diagram

At this S 2000 plug-in-variant you are able to integrate the drive-electronics and the temperature sensor on your own choice. Also you can place it on your PCB.

At the wiring diagram we recommend a drive-electronics with protection for high voltage and reversed polarity.

Blower diagnosis with special equipped drive-electronics possible (wiring diagram on request).

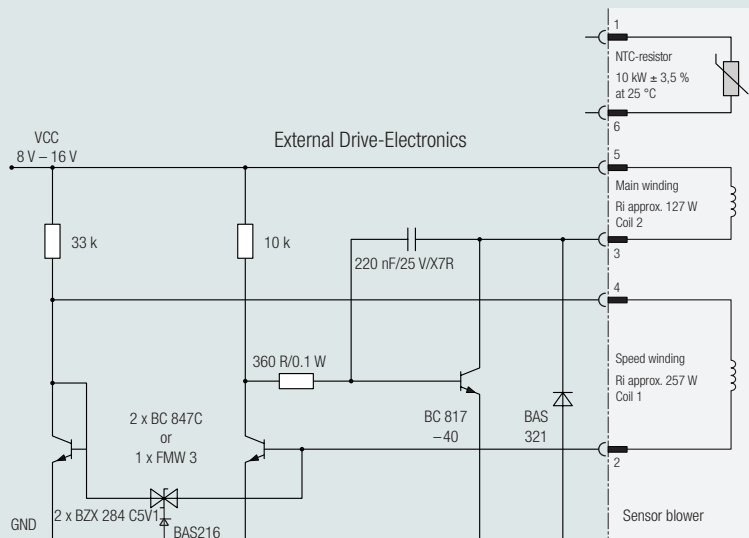

Dimensions

All measures in mm. Engineering drawing with tolerance indication on request.

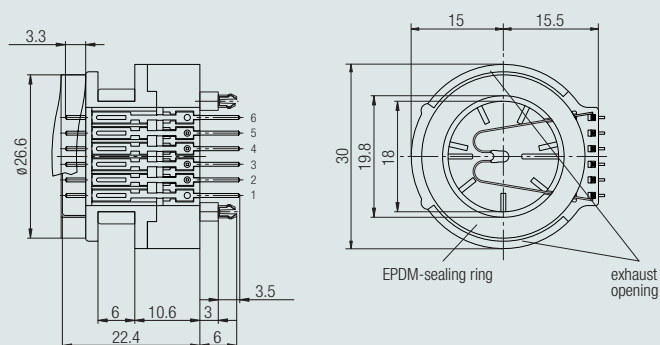

Fixing

Mounting by clip or screw fixing on the PCB.

Electrical terminals via soldering pins (terminals are not suitable for plug-type connection).

Gold plated pins for a direct plug-type connection on request.

